

Hochiki 8 Way I/O Card

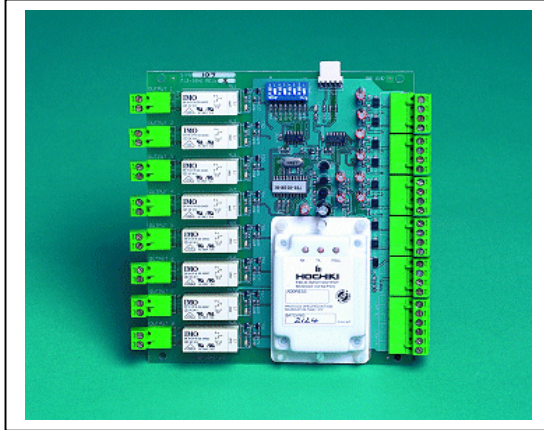

Features

The Mxp-019 is a stand-alone fire system peripheral based on the Hochiki ESP protocol for use with the *Mx-4000* range of panels. The unit connects to the detection loop of the fire panel and provides monitoring for up to 8 individual switch inputs and provides 8 individually programmable 8 Amp rated, volt free, clean contact outputs. In addition, the unit provides monitoring of its local power supply.

In use, each input can be assigned to an individual or common zone, can be configured as monitored or un-monitored and can be individually programmed to generate a specific user defined function from the control panel program. The input functions can be either latched or non-latched and include Fire, Fault, Pre-alarm, Security, Alarm, etc. together with any other programmable input option allowed within the *Mx-4000* system's *Dynamix* zoning facilities.

For the outputs, each one can be individually assigned to an output group and has a number of programmable operational parameters including fail-safe, can-silence, allow walk test and delayed operation. Where outputs on multiple 8-way I/O cards are contained within a common output group, all outputs within the group and connected together on the same detection loop are synchronised.

Models, Sales Order Parts:**MXP-019:** Hochiki 8 Way I/O Card**MXP-019-BX:** Boxed Hochiki 8 Way I/O card**MXP-019-BXP:** Boxed Hochiki 8 Way I/O Card c/w 1A EN54 Power Supply & Charger.

Up to six Mxp-019 cards can also be mounted to the Mxp-023 4A PSU or Mxm-019 Utility enclosure. Please contact sales for further information.

Applications / Limitations:

Ideal for any applications where a number of remote switch inputs and/or outputs have to be interfaced into a fire alarm system. Since the unit only takes up one loop address a large number of I/O can be accessed.

Multiple 8-way outputs programmed to the same output group and connected together on the same detection loop are all synchronised making the card ideal for any application where synchronisation of outputs is required.

Up to a maximum of 60 Mxp-019 can be connected to a single Mx-4000 multi-loop panel and up to 15 to the Mx-4100 control panel (excluding all detection devices).

Compatibility:

The Mxp-019 is compatible with all Mx-4000 control panels using Hochiki ESP protocol from software revision 17-01 onwards.

Item	Specification Details
Inputs	8 programmable inputs that can be unmonitored or monitored for both open circuit and short circuit conditions. Input E.O.L. resistor: 10K Ω \pm 2K Ω Input operating resistor: 470 Ω - 680 Ω Power supply fault input terminal: Closed contact = Normal Open contact = Fault
Outputs	8 Relay outputs capable of switching 230VAC loads up to 8 Amps (resistive).
Transmission Method	Digital Communication using ESP protocol.
Loop current	Quiescent: 350uA When polling: 22mA \pm 20%
On board indication	8 on board output LED's. (LED illuminates when output relay is closed). 1 on board Fault LED. Normal Operation: 1Hz, Fault Operation: 5Hz
Power supply	MXP-019-BXP: 220-240 Volts AC (+10%, -15% tolerance) 50/60Hz MXP-019, MXP-019-BX: 24Vdc @ 200mA
DC Supply Current (for PCB)	Quiescent state (no output relays energised) 18mA All relays energised 160mA
Dimensions (H x W x D)	PCB Only: 160mm (including terminals) x 160mm x 20mm Enclosure: 340mm x 365mm x 125mm
As our policy is one of constant product improvement the right is therefore reserved to modify product specifications without prior notice	

Moorland House : Nelson Park : Cramlington
Northumberland : NE23 1WE
Tel: +44 (0)1670 707 111
Fax: +44 (0)1670 707 222
www.Advel.co.uk Email: Sales@Advel.co.uk



ISO9001



ISO9001

Hochiki 8 Way I/O Card

Installation

These instructions cover the installation, commissioning and programming of the Mxp-019.

When this unit is supplied complete with a power supply (Mxp-019-BXP), refer to the data sheet 680-044 for detailed information regarding the installation of the enclosure and of the power supply equipment.

Fixing Points

The card is provided with four fixing points. The card dimensions and fixing points are as detailed in the diagram opposite.

Use nylon or brass M3 tapped spacer pillars to mount the card within an enclosure suitable for fire protection use and of a minimum IP30 rating. Secure the board with M3 screws.

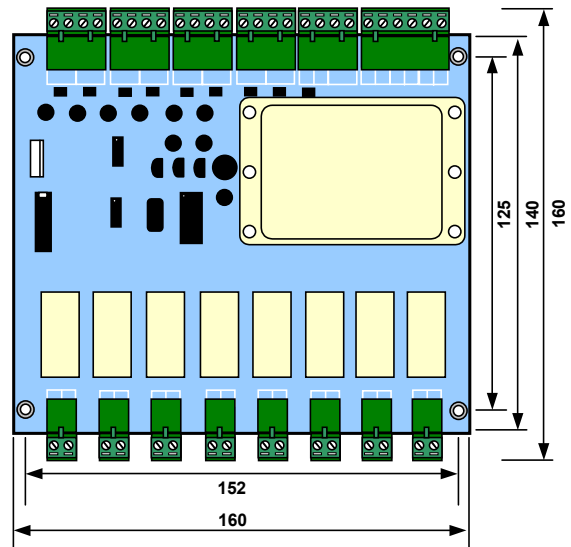

Address Configuration

The device address is set using bits 1 to 7 of the DIL switch. This gives an address range of 1 to 127. Table 1 below shows the arrangement for setting the device address.

Addr	1234567	Addr	1234567	Addr	1234567	Addr	1234567	Addr	1234567
1	●○○○○○	27	●●●●○○	53	●●●○○○	79	●●●○○○	105	●○○●●●
2	○●○○○○	28	○○●●○○	54	○●●○○○	80	○○○○●○	106	○○○○●●
3	●●○○○○	29	●●●●○○	55	●●●○○○	81	●○○○○○	107	●●○○●●
4	○○●○○○	30	○○●●○○	56	○○●●○○	82	○●○○○○	108	○○○○●●
5	○●●○○○	31	●●●●○○	57	○○●●○○	83	●●○○○○	109	●●○○●●
6	○●●○○○	32	○○○○●○	58	○●●○○○	84	○○●○○○	110	○○○○●●
7	●●●○○○	33	●○○○○○	59	●●●○○○	85	●○●○○○	111	●●○○●●
8	○○●○○○	34	○○○○●○	60	○○●●○○	86	○●●○○○	112	○○○○●●
9	●○○○○○	35	●●○○○○	61	○●●●○○	87	●●●○○○	113	●○○○○○
10	○●●○○○	36	○○○○●○	62	○●●●○○	88	○○●○○○	114	○○○○●●
11	●●●○○○	37	●○○○○○	63	●●●●○○	89	●○●○○○	115	●●○○●●
12	○○●○○○	38	○○○○●○	64	○○○○●○	90	○●●○○○	116	○○○○●●
13	○●●○○○	39	●●●●○○	65	●○○○○○	91	●●●○○○	117	●○○○○○
14	●●●○○○	40	○○○○●○	66	○●○○○○	92	○○●○○○	118	○○○○●●
15	●●●○○○	41	●○○○○○	67	●●○○○○	93	●○●○○○	119	●●○○●●
16	○○○○●○	42	○○○○●○	68	○○●○○○	94	○●●○○○	120	○○○○●●
17	●○○○○○	43	●●●●○○	69	○●●○○○	95	●●●○○○	121	●○○○○○
18	○●○○○○	44	○○○○●○	70	○●●○○○	96	○○○○●○	122	○○○○●●
19	●●○○○○	45	●●●●○○	71	●●●○○○	97	●○○○○○	123	●●○○●●
20	○○●○○○	46	○○○○●○	72	○○●○○○	98	○●○○○○	124	○○○○●●
21	○●●○○○	47	●●●●○○	73	○○●○○○	99	●●○○○○	125	●○○○○○
22	○●●○○○	48	○○○○●○	74	○●●○○○	100	○○●○○○	126	○○○○●●
23	●●●○○○	49	●○○○○○	75	●●●○○○	101	●○●○○○	127	●●○○●●
24	○○●○○○	50	○○○○●○	76	○○●○○○	102	○●●○○○		
25	●○○○○○	51	●●●●○○	77	●●●○○○	103	●●●○○○		
26	○●●○○○	52	○○●●○○	78	○●●○○○	104	○○●○○○		

Table 1

ON = ●
OFF = ○

Input Type Configuration

The input mode of operation is set using bit 8 of the DIL switch. The eight inputs can be configured for monitored or non-monitored operation. All inputs must either be monitored or non-monitored. Refer to the wiring section for details of the EOL resistors and wiring arrangement for monitored inputs.

Monitored Inputs - Set to OFF ○
 Non-Monitored Inputs - Set to ON ●

Wiring

The unit is designed for easy wiring installation.

“Plug-in” terminal blocks are provided for all connections to the unit.

The diagram below shows a typical wiring arrangement using “unmonitored” inputs.

NB: Minimum / Maximum cable size for all connections is limited to 0.5mm² / 2.5mm² (22-14AWG).

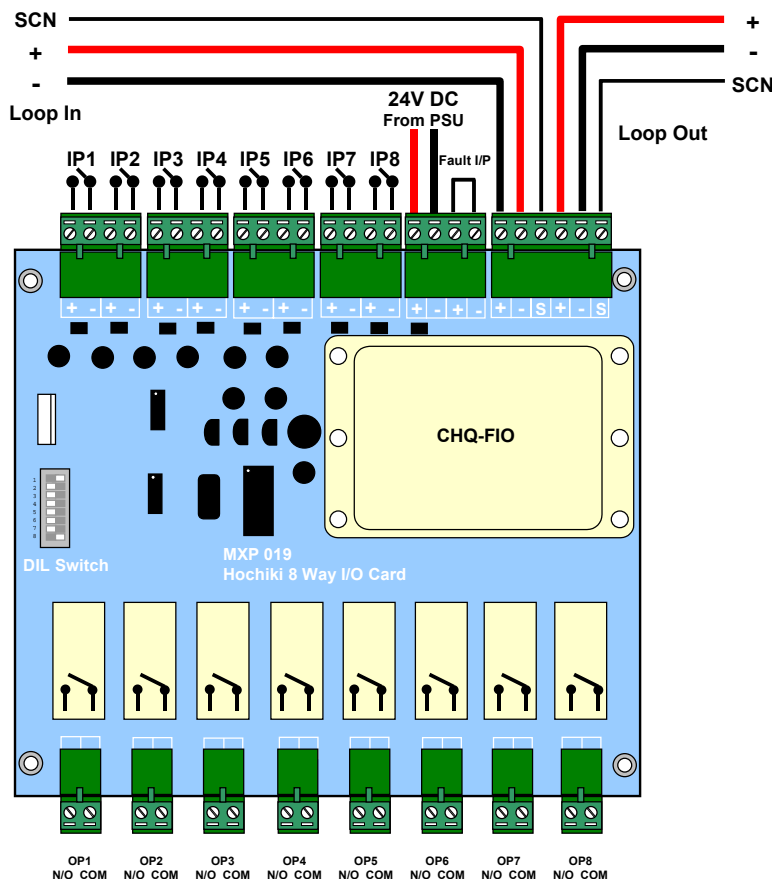

All electrical wiring installation work should be carried out in accordance with the code of practice applicable in the country of installation.

To maintain electrical integrity of the SELV wiring on the loop, input lines and DC power lines all SELV wiring should be segregated from the LV mains wiring and be wired using cable with insulation suitable for the application.

To minimise the effects of EMC interference all data wiring circuits should be wired with a twisted pair of conductors with a cross sectional area suitable for the loading conditions.

In areas where cabling may come into contact with high frequency interference, such as portable radio transceivers etc. the data wiring cable should be of a twisted pair construction within an overall screen. The screen should be terminated to a suitable earth point in the enclosure close to the point of entry.

Loop Wiring

Connect the module to the detector loop via the Loop '+' and '-' terminals.

Break the wiring run to maintain loop line supervision and connect to the IN and OUT terminals.

Connect the screen of the cable to the appropriate SCN terminals. Ensure that the screen is not exposed to any other ground or earth point.

For more information on loop wiring, refer to the Panel Installation and Commissioning Manual.

Power Input Wiring

Connect the 24V DC supply feed to the SUPPLY +24V and GND terminals.

Note: The power supply used MUST BE designated a Safety Extra Low Voltage (SELV) supply.

Use cable of a suitable size and rating to ensure that the voltage at the input is not less than 19V DC under all conditions of AC Mains and Battery Voltages.

Fault Input Wiring

The "FLT IP" terminals are normally used to monitor the "normally closed" contacts of the fault relay output from the power supply.

If more than one module is powered from the same power supply, it is only necessary to connect the fault output monitoring to one of the modules.

The Mxp-019-BXP is pre-configured for this mode of operation.

Should no fault relay be available, or if the monitoring of an external fault signal is not required, these two terminals should be shorted together.

Switch Input Wiring

For non-monitored inputs wire the switch contacts direct to the '+' and '-' terminals of the required input on the unit.

For monitored inputs, the circuits should be wired as per the diagram opposite.

The 470Ω (operating) resistor and 10KΩ (E.O.L) resistor arrangement should be made adjacent to the switch contacts to ensure that correct fault monitoring of the total circuit (including the wiring) between the input contact and the Hochiki 8 way I/O unit is maintained.

If input monitoring is selected, ensure that there is a 10KΩ E.O.L resistor across any unused input terminals.

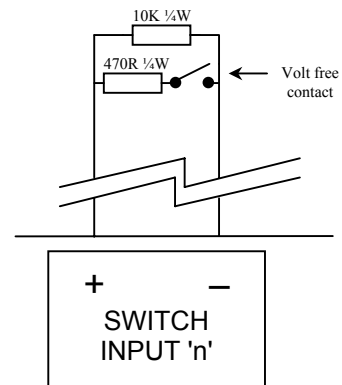

Output Wiring

Connect the output wiring to the COM and NO terminals.

Refer to the specification section for the maximum voltage and current switching capability of the relays.

Use cables of appropriate size for the voltage and loading required. All cables should be to the same voltage and insulation specification appropriate to the intended application.

NB: Route ALL wiring away from SELV circuits (DC Power Wiring, Loop Wiring and Input Wiring).

Operation

Once the supply is turned on, the on-board fault LED will flash at a rate of 1Hz if all connections to the unit are OK. Should an input open or short circuit be detected when input monitoring is enabled or if the "FLT IP" connection is open circuit, this LED will flash at a rate of 5Hz.

Auto-learn the devices on the loop according to the procedure set out in the panel's Installation and Commissioning manual.

Programming

Each input and output can be independently programmed in the same way as other inputs and outputs on the system.

The outputs also appear as 'loop' devices. These are shown as 'relay outputs' with sub addresses 8 through 15.

On the PC configuration software, the inputs appear as 'loop' devices. These are shown as 'switch inputs' with sub addresses 0 through 7.

Double-click on the device icon to bring up "Device Details". The input action, delay etc. can then be defined.

For further information on PC programming, see document reference 680-021.

The screenshot shows the 'Mx Series Configuration Software (3.00)' interface. The main window displays 'Device Information :- Loop 1' for an 'I/O Module (CHQ-FIO)'. On the left, a tree view shows the system structure: 4400 # Node1 (Sector 1) containing On-Board, Loop 1, Loop 2, Loop 3, and Loop 4. The central table lists the following devices:

Address	Type	Device Location Text	Zone
1.0	Switch		1
1.1	Switch		1
1.2	Switch		1
1.3	Switch		1
1.4	Switch		1
1.5	Switch		1
1.6	Switch		1
1.7	Switch		1
1.8	Relay		1
1.9	Relay		1

At the bottom of the window, status bars show: Modified, Points Used - 3%, Output Rules Used - 0%, Quiescent 330µA, and Alarm 330µA.

Output Group Synchronisation

Like the Hochiki CHQ-BS loop powered sounder, FIO devices can also have their outputs synchronised. Relays on multiple FIO devices, assigned to the same output group number, will all operate at the same time.

Note: For applications where CHQ-BS and FIO devices are fitted to the same loop, ensure that they do not share the same output group number, otherwise the relays will respond along with the sounders to silence / resound operations (which may not be the intention).