

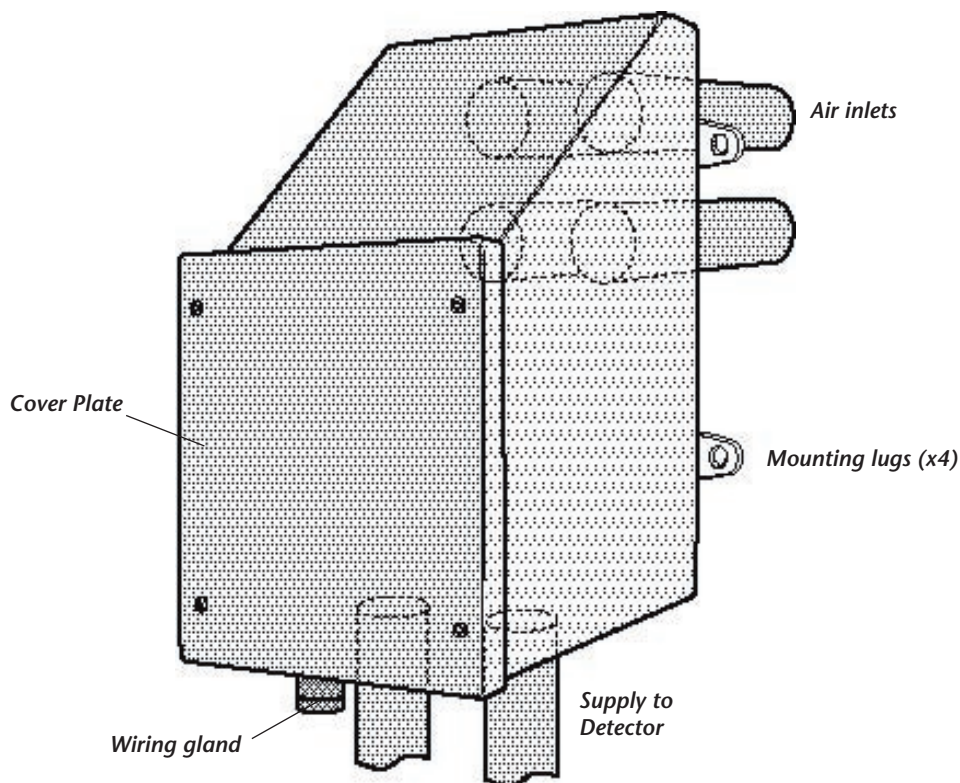

Air Heater Assembly for Low Temperature Applications

Overview

Stratos-HSSD[®] detectors are unsuitable for installation within an area if the ambient temperature is expected to fall below 0°C (minimum operational temperature of the detector is -10°C). Where the air temperature in the protected area is consistently below these temperatures it is imperative the *Stratos-HSSD* is mounted outside the protected area. The Air Heater assembly is designed to raise the temperature of air drawn from a very cold environment by passing it across a heating element just as it leaves the protected area. In this manner the problem of condensation on sampling pipework external to the protected area is minimised. Warming the air sample will also ensure the components of the *Stratos-HSSD* operate within the specified temperature tolerances and reduces the possibility of surface condensation.



Components

- Fabricated sheet steel enclosure and access cover. Surface finish is passivated zinc plated.
- Self-regulating heating element - 230 VAC 60/200 Watts.
- Inlets - 4 x 3/4 inch male ABS tank connector. (25mm optional). If metallic sampling pipe is to be used these can be changed to the appropriate connectors.
- Outlets - 2 x 3/4 inch male ABS tank connector.
- Cable entry gland.
- Ceramic terminal block.

Installation

- Ensure that the temperature of the selected location is within the operating limits of the Stratos-HSSD® detector (-10 to 60°C).
- The heater assembly should ideally be mounted approximately 300mm above the Stratos-HSSD detector. To simplify interconnection threaded socket unions should be used.
- Once the position of the unit has been determined a penetration should be made through into the protected area corresponding to the position of the sampling pipe inlets. This penetration should be no larger than 105 x 105mm.
- If the mounting site is corrugated or uneven, fix a mounting plate or board first.
- Offer the unit up to the opening and mark the position of the holes for the four mounting fasteners.
- Fix the unit to the selected location with appropriate round or pan head fasteners.
- Connect ABS sampling pipes to the inlets using joining sockets. (When using sampling pipes in other materials it may be necessary to fit stubs prior to fixing the heater unit.)
- Cap or plug off any unused inlets ensuring that the seal is airtight and cannot easily be broken.
- Connect the heater assembly to two of the Stratos-HSSD inlets.
- Make electrical connections to the heater unit using either a 3-core 1.5mm heat resistant flex or MICV. To simplify termination within the enclosure it is recommended the ceramic terminal block be temporarily released from its two fixing screws.
- The electrical supply should be from a 230 V.AC unswitched spur fused at 3A.
- The heater assembly must be earthed.

Monitoring Option

To monitor the operation of the air heater element, a precision air thermostat kit is available. This monitors the temperature of the sampled air as it leaves the aspirating fan assembly. If the heater element fails, the changeover contacts of this thermostat can be connected to signal a Common Fault. When the *Stratos-HSSD* is connected to an analogue addressable fire alarm system, a monitoring interface can be used to give a specific fault warning.



AirSense Technology Limited

71 Knowl Piece • Wilbury Way • Hitchin • Hertfordshire • SG4 0TY
Tel. +44(0)1462 440666 • Fax. +44(0)1462 440888
e-mail: technical@airsense.co.uk • www.airsensetechnology.com